



straumann



Fodder mixing wagon

**Verti-Mix
Double K**



Verti-Mix Double K

The slim easy to tow two-auger mixer

Various discharge options

- Side door
 - Two-sided fodder discharge
 - Optional conveyor extensions
- Crossover conveyor
 - PVC conveyor with lattice bar roller for long service life
- At the rear centre
 - e.g. for preparation of premixtures

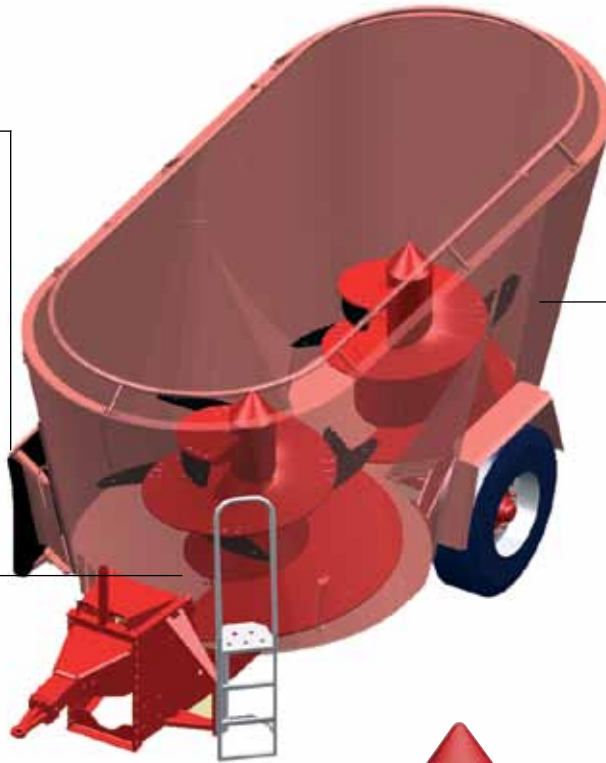

Unique container shape

- Conical rear part with smaller mixing auger
- Enables positioning of tyres beside the container without any effects on the vehicle width
- Large tyres possible – for better manoeuvrability and excellent running characteristics

Homogeneous mixing by means of Vario mixing auger

The Vario mixing auger – Variability and strength for any purpose.

Due to the patented knife adjustment system, the Vario mixing auger can be perfectly adapted to your specific conditions of use.

The robust and low-maintenance angular gear ensures long service life even under challenging conditions. The Vario mixing auger is available with a magnetic system as an optional extra, which is mounted directly at the auger, thus being in perfect contact with the fodder. So, the efficient separation of metal actively contributes to protecting the health of your high-yield cows.

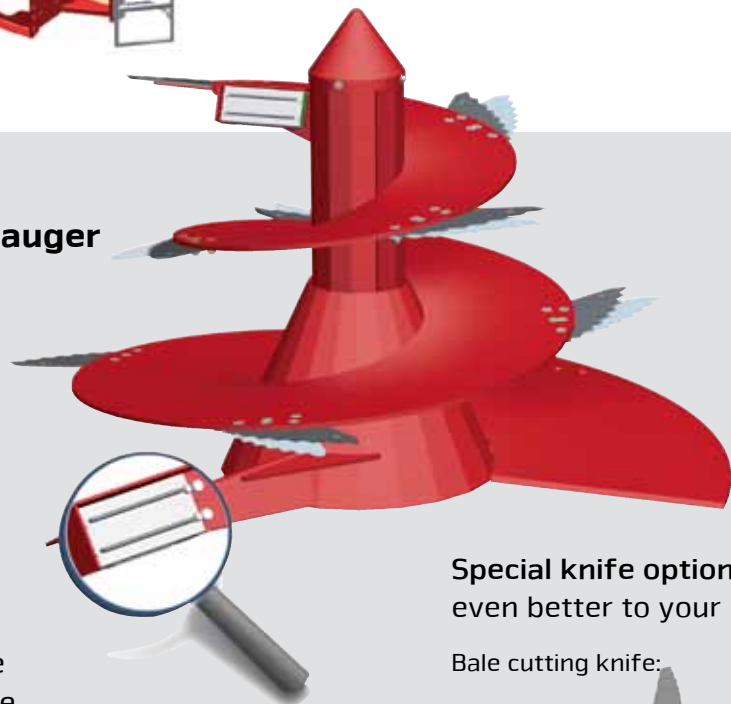

Special knife options help to adapt even better to your needs:

Bale cutting knife:

Straw knife:

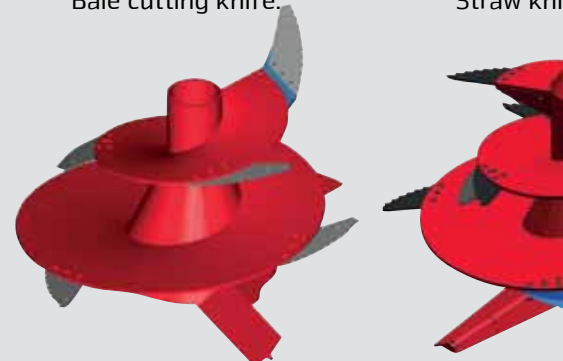

Weighing & operating



- PTM HL 50**
- Programmable weighing device
 - 50 recipes
 - 30 ingredients



- PTM Super Grafik USB**
- Programmable weighing device with data transfer
 - 150 recipes
 - 30 ingredients
 - Read-out and management by means of included software



- Radio remote control PTM AV 50 & Super Grafik**
- Matching the PTM HL 50
 - Up to 30 m of range



Direct tractor connection
Requires one double-acting control device at the tractor for each function



Operation via Bowden cable
One double acting control device at the tractor or one single-acting control device with free return line required



Electrical control set
One double acting control device at the tractor or one single-acting control device with free return line required



Fodder mixing wagon Verti-Mix 1300 – 2100 Double K

Technical data

Type		VM 1300 Double K	VM 1500 Double K	VM 1800 Double K	VM 2100 Double K
Dimensions					
Length with rear crossover conveyor	m	5,97	5,97	6,41	6,41
Length without crossover conveyor	m	5,80	5,87	6,28	6,36
Width with rear crossover conveyor	m	2,16	2,16	2,42	2,42
W. w. one-sided right-hand front discharge	m	2,26	2,26	2,52	2,52
W. w. one-sided left-hand front discharge	m	2,28	2,28	2,54	2,54
W. w. two-sided right a. left front discharge	m	2,38	2,38	2,64	2,64
Height approx.	m	2,36	2,58	2,61	2,86
Usable mixing capacity *	m ³	13	15	18	21
Gross vehicle weight rating	kg	11.800	11.800	12.000	12.000
Dead weight approx.	kg	4.860	5.330	6.150	6.610
Track	m	1,85	1,85	2,06	2,06
Outside wheel width	m	2,17	2,17	2,45	2,45
Discharge height	m	0,57	0,57	0,57	0,57
Container wall thickness	mm	8	8	8	8
Bottom plate	mm	20	20	20	20
Dimensions of tyres		315/80 -22,5 re.		385/65 R 22,5 re.	

* Actually usable mixing capacity, augers having been deducted from the capacity

Power required for Verti-Mix 1300 – 2100 Double K

	rpm/min	kW/HP	kW/HP	kW/HP	kW/HP
without switchgear	20	46 / 63	50 / 68	-	-
without switchgear	24	57/78	71/97	81/110	88/120
with switchgear	16 / 24	41 / 55	44 / 60	-	-
with switchgear	13 / 24	-	-	50 / 67	54 / 74
without switchgear	29	75/102	81/110	91/124	100/36
with switchgear	19 / 29	46 / 63	50 / 68	-	-
with switchgear	16 / 29	-	-	56 / 76	62 / 84

your Vario mixing auger

fe (long/short):

Root crop knife:

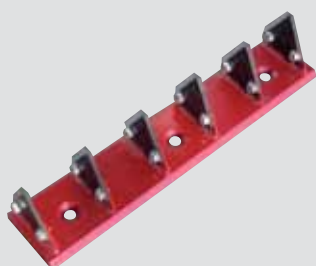



strautmann



Strautmann main production facility in Bad Laer

B. Strautmann & Söhne GmbH u. Co. KG is a medium-sized family-owned company from southern Lower Saxony having already celebrated its 80th anniversary of existence and now being managed by the third generation. In a modern plant at the second production site in Lwówek (Poland), Strautmann manufactures individual machine components and, apart from that, also parts of the

machine programme such as tipping trailers, silage shovels or shear grabs. As a machine manufacturer offering a wide range of machinery for cattle feeding, green fodder harvesting, universal spreader and transport technology as well as in the field of charging and dosing technology for biogas plants Strautmann is the suitable partner for almost any customer in this industry.



Pol-Strautmann



002 / 04.2014

B. Strautmann & Söhne GmbH u. Co. KG

Bielefelder Straße 53 · D-49196 Bad Laer · Tel.: +49(0)5424/802-0 · Fax: +49(0)5424/802-76 · info@strautmann.com · www.strautmann.com