

INSTALLATION OF DOWN FORCE KIT 9079 ON DANUSER MODELS F7, F7A, F7U, F8 & 8700

For view of the DOWN FORCE KIT, refer to back of this page.

TRACTOR MUST BE EQUIPPED WITH A 3-WAY OR 4-WAY REMOTE VALVE AND OUTLETS.

WARNING

Refer to owner's manual for safety related contents concerning, assembly, installation, and operation.

Remove implement from tractor before any installation begins.

Remove pin securing digger yoke to digger boom.

Install R.H. cylinder support 9075 and L.H. cylinder support 9067 on boom pivot boss. Reassemble yoke to boom.

Install spacer 9077 between cylinder supports and secure with bolt 8034, lockwasher 973, and nut 1056. Do not tighten nut.

Assemble upper 9071 and lower 9070 clamp assemblies loosely to digger boom using bolts 1582, lockwashers 973, and nuts 1056.

Assemble hydraulic valve assembly 6232 with its 3/8 inch male elbow end to cylinder 9076 using appropriate hydraulic joint sealant, being careful not to cross thread the elbow fitting with the cylinder threaded boss.

Position the hydraulic valve assembly input port facing the tractor hitch end of the digger boom.

Attach digger to tractor according to owner's manual. Check for clearance between the boom end and your tractor as you raise the digger to the maximum height.

Attach head end of cylinder, with elbow and hydraulic valve assembly up, to upper ends of cylinder supports using pin 9080 and klik-pin 1600. Collapse cylinder to its minimum length and attach cylinder rod to clamp 9071 with pin 9078 and klik-pin 1600.

Push upper ends of cylinder supports 9067 and 9075 forward so that lower ends are resting firmly against yoke. Extend cylinder approximately 3/4 inch by sliding clamp assembly on boom and tighten clamp securely in this position. Tighten bolt 8034, securing spacer 9077 between cylinder supports.

The hoses and fittings to connect the tractor output and the return sump line should be obtained locally.

The connection to sump can be made at oil fill, oil level check, breather or drain opening. However, it is preferable to connect at a point below the oil level.

The thread for the input port of the hydraulic valve assembly 6232 is 1/2 inch "NPTF" and the return sump line connection at the street tee of the valve assembly is 1/2 inch NPTF.

OPERATION

The down force kit provides approximately 500 pounds of additional force to the auger for drilling through tough digging conditions. To apply down force to auger, move the remote control lever in the proper direction to apply pressure to the hydraulic valve assembly. As long as the lever is held in position, force will be applied. When lever is returned to neutral, the down force cylinder is automatically connected to the system sump and digger can be raised, lowered, and otherwise operated in a normal manner.

DANUSER DIGGER DOWN FORCE KIT

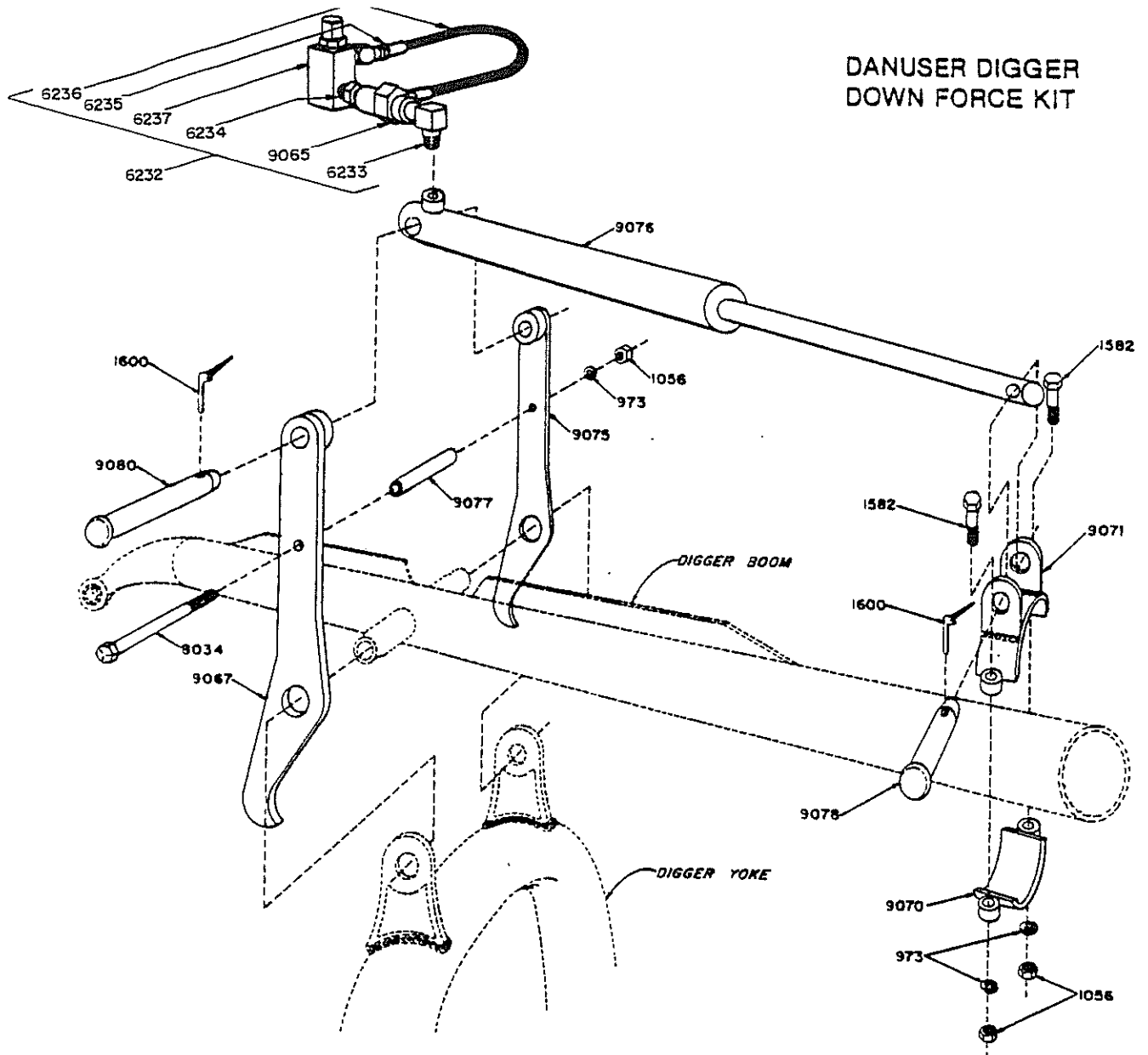

PART NO.	DESCRIPTION	NO. REQ.
9079	DOWN FORCE KIT includes:	1
973	Lock Washer - 1/2 inch	3
1056	Nut - 1/2-13	3
1582	Bolt - 1/2-13 x 2-1/2 inch	2
1600	Klik Pin	2
8034	Bolt - 1/2-13 x 5-1/2 inch	1
9065	Valve	1
9067	Cylinder Support L.H.	1
9070	Lower Clamp Assembly	1
9071	Upper Clamp Assembly	1
9075	Cylinder Support R.H.	1

PART NO.	DESCRIPTION	NO. REQ.
9076	Cylinder (Order Seal Repair Kit 9096)	1
9077	Spacer	1
9078	Clevis Pin - 1 x 3-5/16 inch	1
9080	Clevis Pin 1 x 5-15/16 inch	1
6232	HYDRAULIC VALVE ASSEMBLY includes:	1
6236	Hose - 3/8 x 15 inch	1
6233	Male Pipe Elbow - 3/8 inch x 90°	1
9065	Valve	1
6234	Hex Nipple - 3/8 x 1/2 inch	1
6237	Relief Valve	1
6235	Street Tee - 1/2 inch	1

IMPORTANT: When ordering parts please furnish PART NUMBER, and DESCRIPTION.

HYDRAULIC VALVE ASSEMBLY
6232

